

Penthouses Brochure

CENTRE HEIGHTS SWISS COTTAGE

LONDON NW3

5 minutes from
Regents Park



CENTRE HEIGHTS SWISS COTTAGE





5 km from the Centre Heights
Swiss Cottage



CENTRE HEIGHTS SWISS COTTAGE

A rare opportunity to purchase **triplex penthouses with roof garden** in one of the most exclusive and sought after addresses: Finchley road in Swiss Cottage.

“**Centre Heights**” is a newly refurbished building designed to meet every need of high-profile and VIP residents accustomed to the highest quality.

Elegant and contemporary, the interiors were conceived and designed by the vendors to meet every human comfort with innovative ease.

Next to the Swiss Cottage tube station
Baker Street 5 minutes
Oxford Street 10 minutes

These impressive **triplex penthouses** are set to be completed to the highest of standards boasting distinctive contemporary style and beautiful parquet wood flooring.

KEY FEATURES

- Bespoke Italian kitchens, individually designed for each apartment
- A stunning new development in the heart of Swiss Cottage next to Swiss Cottage tube station, 5 minutes drive to the spectacular Regents Park and London Zoo.
- 5 minutes from Baker Street W1
- On - site Management, concierge and security
- Individual video entry system
- Bicycle storage

LOCAL AREA

London’s Jubilee Line is right on your doorstep, with transport services to West End, Westminster and all airports





CENTRE HEIGHTS SWISS COTTAGE



Spectacular
London Skyline Views



CENTRE HEIGHTS SWISS COTTAGE

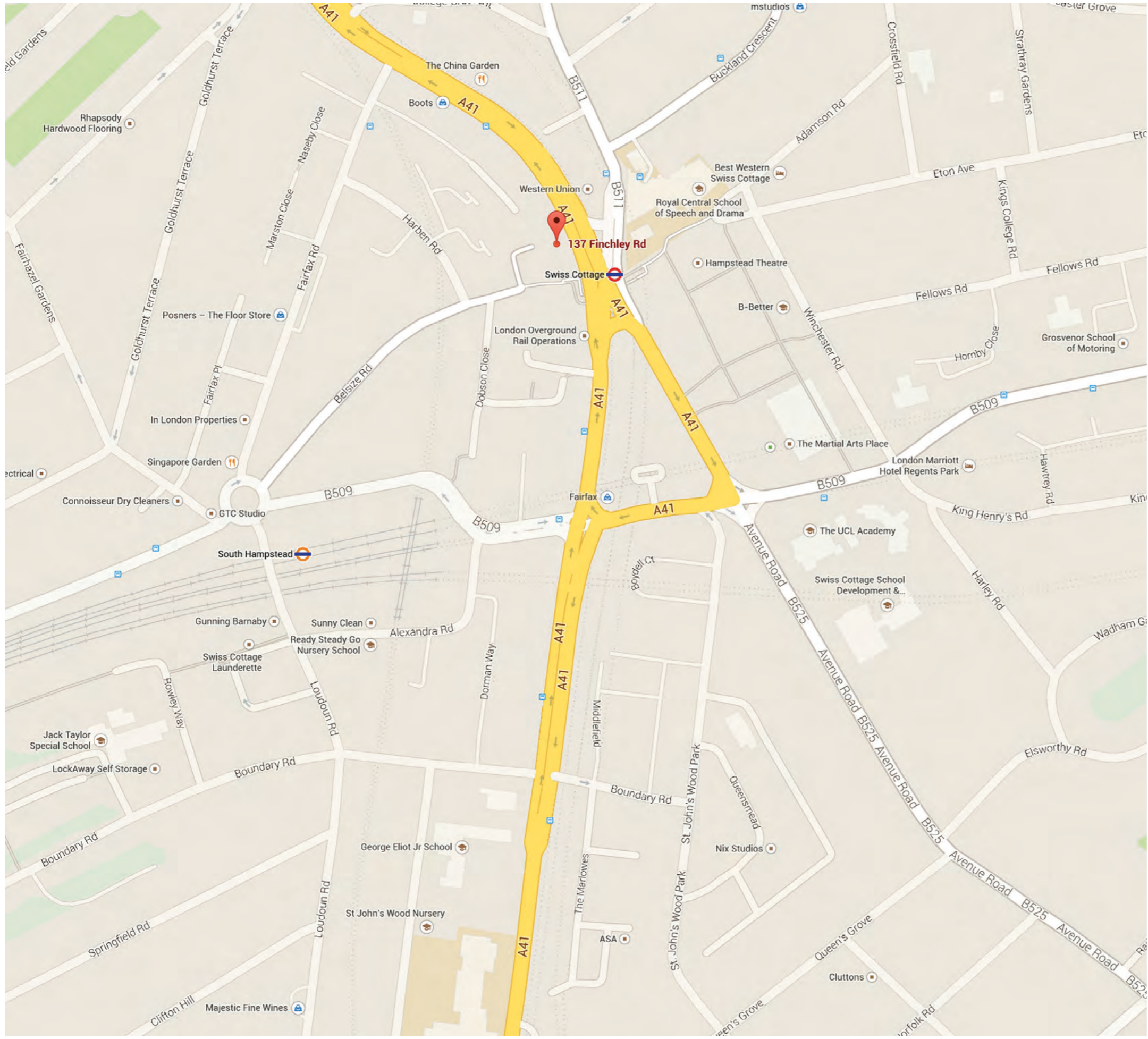

Energy Efficiency Rating

	Current	Potential
Very energy efficient - lower running costs		
(92-100) A		
(81-91) B		
(69-80) C		
(55-68) D	63	65
(39-54) E		
(21-38) F		
(1-20) G		
Not energy efficient - higher running costs		
England & Wales	EU Directive 2002/91/EC	

Energy Impact (CO₂) Rating

	Current	Potential
Very environmentally friendly - lower CO ₂ emissions		
(92-100) A		
(81-91) B		
(69-80) C		
(55-68) D	59	61
(39-54) E		
(21-38) F		
(1-20) G		
Not environmentally friendly - higher CO ₂ emissions		
England & Wales	EU Directive 2002/91/EC	

CENTRE HEIGHTS SWISS COTTAGE

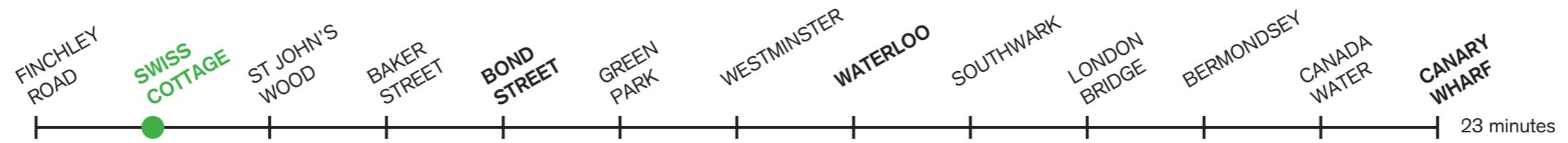



Unit 1

3 Bed Mais.
54.16 m²

Unit 2

3 Bed Mais.
61.53 m²

Unit 3

3 Bed Mais.
61.53 m²

Unit 4

3 Bed Mais.
61.53 m²

Unit 5

3 Bed Mais.
53.77 m²

Eleventh Floor



Unit 1

**3 Bed Mais.
77.77 m²**

Unit 2

**3 Bed Mais.
79.68 m²**

Unit 3

**3 Bed Mais.
79.51 m²**

Unit 4

**3 Bed Mais.
79.68 m²**

Unit 5

**3 Bed Mais.
79.18 m²**

Twelfth Floor

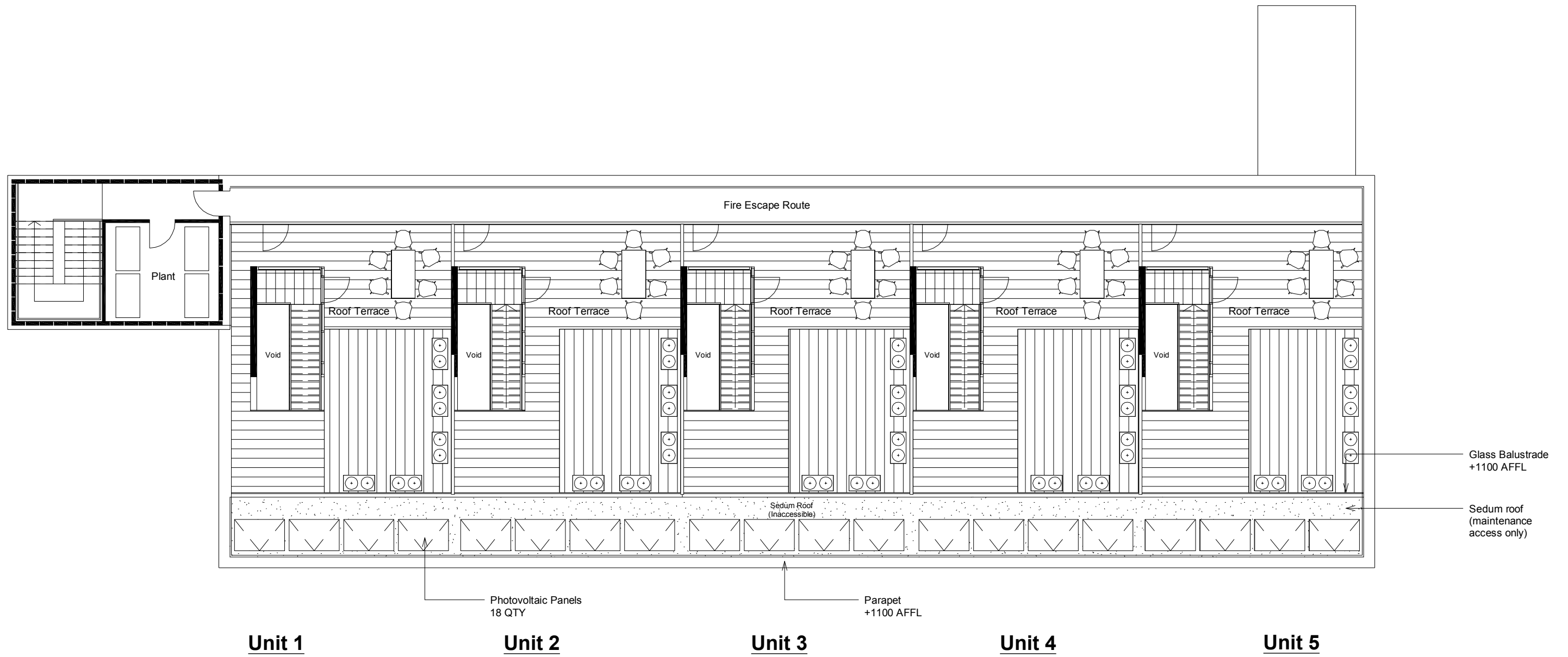

Thirteenth Floor







TECHNICAL SPECIFICATIONS FOR CENTRE HEIGHTS – 18-11-14

TECHNICAL SPECIFICATIONS **CENTRE HEIGHTS**

KITCHENS

- CABINETS HIGH QUALITY ITALIAN BRAND LAMINATE
- WORKTOPS AND UPSTANDS – CORIAN WHITE OR GRANITE OR SILES STONE BLANCO ZEUS
- ELECTROLUX STAINLESS STEEL SINGLE OVEN + ELECTOLUX MICRO WAVE
- ELECTROLUX FULL INT. CHIMNEY
- ELECTROLUX FRIDGE/FREEZER
- ELECTROLUX WASHER/DRYER
- 1 BOWL SINK CORIAN OR S.STEEL 50CM
- BIANCO CULINA S MINI KITCHEN TAP BM 519844 S.STEEL

BATHROOMS AND EN SUITES

- IDEAL STANDARD 'CONCEPT' WC BACK TO WALL E7916
- CORIAN WHITE OR PORCELAN BASIN
- SHOWER TRAY CORIAN OR ACRYLIC SHOWER TRAY
- BASIN MIXER HANSGROHE LOGIS CHROME – 71220000
- SHOWER MIXER HANSGROHE – ECOSTAT S1575800 + RAIN SHOWER RAINDANCE SELECT – 26469000 + RAINDANCE SELECT 150 3JET HAND SHOWER
- HEATED TOWEL RAIL
- BATH SCREEN – FRAMELESS CLEAR TEMPERED GLASS

FINISHES

- WALLS IN EMULSION OFF WHITE
- GYPSUM BOARD CEILINGS OFF WHITE
- SKIRTINGS AS ENG FLOORING

HEATING & LIGHTING

- UNDERFLOOR HEATING
- PROGRAMMABLE THERMOSTAT TO INDIVIDUAL APARTMENTS
- PELMET LIGHTING FOR KITCHEN CABINETS
- DOWN LIGHTS SPOT LED
- ENERGY EFFICIENT LIGHTING

WINDOWS & DOORS

- MAT WHITE INTERNAL DOORS
- DOUBLE GLAZED WINDOWS WITH CHROME IRONMONGERY
- BALCONY/PATIO DOORS TO MATCH WINDOWS
- FLEXIBLE BESPOKE FURNITURE AND FITTINGS (SLIDING FOLDING DOORS TO OPEN-UP BEDROOMS)
- ALUMINIUM: COLOURED DOUBLE GLAZED

SECURITY

- SPY HOLE VIEWER TO FRONT DOOR
- VIDEO ENTRY PHONE
- ON – SITE PROPERTY MANAGEMENT AND SECURITY

WARDROBE

- HIGH QUALITY ITALIAN BRAND

HOME ENTERTAINMENT / COMMUNICATIONS

- TERRESTRIAL TV/FM SOCKET TO LIVING ROOM AND BEDROOM(S)
- SKY + TV MASTER SOCKET IN LIVING ROOM

FLOORING

- LIVING ROOM, KITCHEN, BEDROOMS ENG WOOD PARADOR –BASIC 11-5 OAK TABACCO BLOCK 3 PLANK RUSTICAL LAQUERD FINISH WITH ACUSTIC PROTECT 200 UNDERLAY
- WC RECTIFATE CERAMIC TILES ABK ROCKWAY STONE FLOOR 60X60 – WILLS 15X60

INTERNAL COMMUNAL AREAS

- MARBLE AND WOOD PANEL WALLS AND FLOORING TO COMMUNAL ENTRANCE FOYER, MARBLE EMPERADOR DARK AND STAIR CASE KOHARA MARBLE OR SIMULAR
- BALUSTER WITH OAK CAP AND CLEAR GLASS LAMINATE 15MM
- EIGHT PERSON PASSENGER LIFT TO SELECTED STAIR CORES
- FIRE ALARM SYSTEM PROTECTION OF COMMON AREAS
- BICYCLE STORAGE WILL BE PROVIDED OUTSIDE

WARRANTY

- TEN YEAR PREMIER BUILDING WARRANTY

WASHING MACHINE / DRYER



FRIDGE



ELECTROLUX FULL INT CHIMNEY



ELECTROLUX MICRO WAVE



HOBS



ELECTROLUX S.STEEL SINGLE OVEN



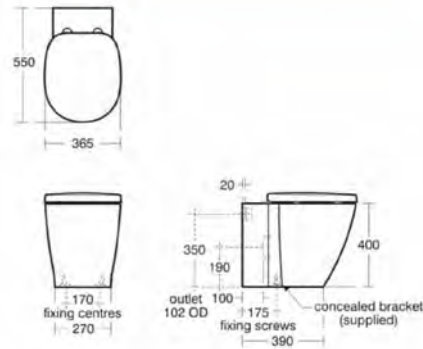

Back to Wall WC

Concept back to wall WC pan with horizontal outlet

Standards

Vitreous china to BS 3402. WC pan to BS EN 997 & BS EN 33

Finishes*

01

Required

TOILET SEAT AND COVER	E7918
TOILET SEAT AND COVER, SLOW CLOSE	E7917
UNIVERSAL HEIGHT, TOP INLET CISTERN - PNEUMATIC DUAL FLUSH VALVE - NO FLUSHPLATE...	S3624

*Finishes: 01 = White

Logis

Single lever basin mixer for concealed installation with spout 195 mm wall-mounted
 Surfaces: chrome Art. no. : 71220000



Description

product features

- handle can be positioned on the right or left, depends on the basic set installation
- spout 195 mm long
- normal spray
- flow rate: 5 l/min
- flush grated waste - water flow cannot be stopped
- QuickClean system for easy limescale removal

Mandatory Accessories

- Basic set for single lever basin mixer for concealed installation (#13622XXX)

Article Details

Price incl. VAT* £ 186.00

Technology



Product image



Scale drawing

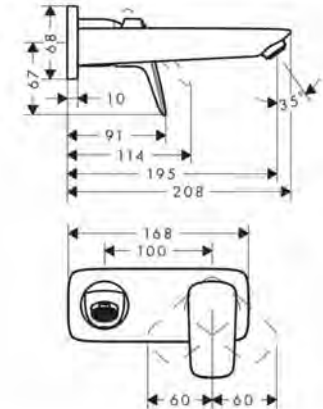

Raindance

Raindance Select 150 3jet hand shower

Surfaces: white/chrome Art. no. : 28587400



Description

product features

- shower head size: 150 mm
- Select button to comfortably switch between spray modes
- spray type: RainAir (rain jet enriched with air), CaresseAir, Mix
- maximum flow rate (at 3 bar): 16 l/min
- operating pressure: min. 1.5 bar / max. 6 bar
- easy to clean, white spray face

Article Details

Price incl. VAT* £ 103.20

Technology



Design awards



Product image



Scale drawing

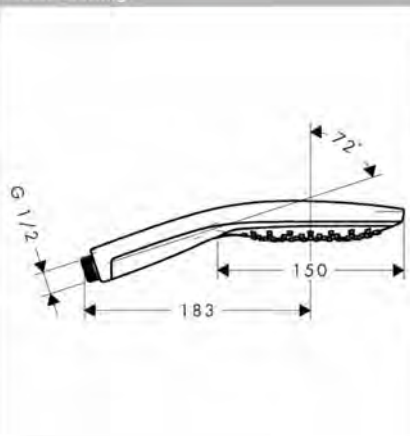

Ecostat S

Ecostat S thermostatic mixer for concealed installation with integrated shut off/diverter valve

Surfaces: chrome Art. no. : 15758000



Description

product features

- designed to run 2 outlets
- safety stop at 40°C
- flow rate: 26 l/min
- wall-mounted

Mandatory Accessories

- iBox universal basic set 1/2 and 3/4 (#01800XXX)

Optional Accessories

- Extension Set 150mm (#13597XXX)
- Extension 25mm for iBox universal (#13595XXX)

Article Details

Price incl. VAT* £ 399.00

Product image



Scale drawing

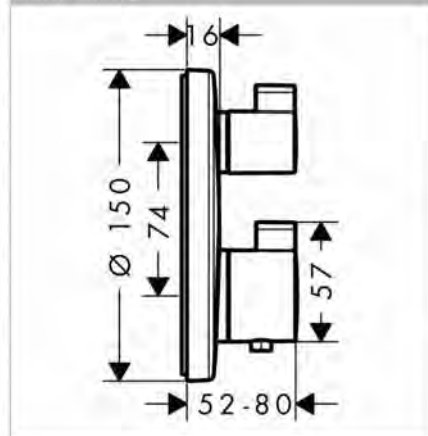

Raindance Select

Raindance Select S 240 2jet EcoSmart overhead shower with ceiling connector

Surfaces: chrome Art. no. : 26469000



Description

product features

- shower head size: 240 mm
- spray type: RainAir (rain jet enriched with air), Rain
- flow rate Rain (at 3 bar): 9 l/min
- flow rate RainAir (at 3 bar): 9 l/min
- spray type selection: Select button on overhead shower
- spray face surface in two variants: chrome or white
- material spray face: metal
- spray disc removeable for cleaning
- Ceiling connection length: 100 mm
- installation type: ceiling

Article Details

Price incl. VAT*

£ 354.00

Technology



Product image



Scale drawing

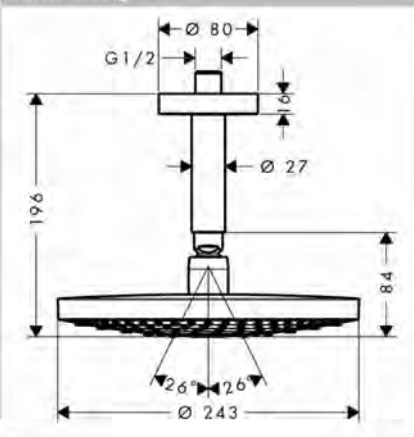

ROCKWAY 01

CARATTERISTICHE TECNICHE / TECHNICAL CHARACTERISTIC



CLASSIFICAZIONE SECONDO NORME UNI EN 14411 (ISO 13006) ALLEGATO D Gruppo B1a GL
 CLASSIFICATION IN ACCORDANCE WITH UNI EN 14411 (ISO 13006) APPENDIX D-Group B1a GL

GRES PORCELLANATO A MASSA COLORATA COLORED BODY PORCELAIN TILES	NORMA NORM	VALORE PRESCRITTO DALLE NORME VALUE PRESCRIBED FROM THE NORMS	VALORE ABK ABK VALUE	VALORE ABK ABK VALUE
LUNGHEZZA E LARGHEZZA DIMENSIONE MEDIA DI OGNI PIASTRELLA LENGTH AND WIDTH OF THE AVERAGE-SIZES TILE	UNI EN ISO 10545/2	$\pm 0,5\%$	CONFORME ACCORDING	CONFORME ACCORDING
SPESSORE THICKNESS	UNI EN ISO 10545/2	$\pm 5\%$	CONFORME ACCORDING	CONFORME ACCORDING
RETTILINEARITÀ SPIGOLI WARPAGES OF EDGES	UNI EN ISO 10545/2	$\pm 0,5\%$	CONFORME ACCORDING	CONFORME ACCORDING
ORTOGONALITÀ WEDGING	UNI EN ISO 10545/2	$\pm 0,6\%$	CONFORME ACCORDING	CONFORME ACCORDING
PLANARITÀ FLATNESS	UNI EN ISO 10545/2	$\pm 0,5\%$	CONFORME ACCORDING	CONFORME ACCORDING
ASSORBIMENTO D'ACQUA WATER ABSORPTION	UNI EN ISO 10545/3	$\leq 0,5\%$	CONFORME ACCORDING	CONFORME ACCORDING
RESISTENZA ALLA FLESSIONE BENDING STRENGTH	UNI EN ISO 10545/4	$\geq 35 \text{ N/mm}^2$	CONFORME ACCORDING	CONFORME ACCORDING
FORZA DI ROTTURA BREAKING STRENGTH	UNI EN ISO 10545/4	$\geq 1300 \text{ N}$	CONFORME ACCORDING	CONFORME ACCORDING
RESISTENZA AGLI SBALZI TERMICI THERMAL SHOCK RESISTANCE	UNI EN ISO 10545/9	RICHIESTA REQUIRED	RESISTE RESISTS	RESISTE RESISTS
RESISTENZA AL GELO FROST RESISTANCE	UNI EN ISO 10545/12	RICHIESTA REQUIRED	INGELIVO FROST PROOF	INGELIVO FROST PROOF
RESISTENZA ALL'ATTACCO CHIMICO CHEMICAL RESISTANCE	UNI EN ISO 10545/13	-	RESISTE RESISTS	RESISTE RESISTS
RESISTENZA ALLE MACCHIE RESISTANCE TO STAINING	UNI EN ISO 10545/14	GL \geq MINIMO CLASSE 3	RESISTE RESISTS	RESISTE RESISTS
COEFFICIENTE D'ATTRITO DINAMICO DYNAMIC FRICTION COEFFICIENT	B.C.R.A. C.A.	<small> 0,40 - μ = 0,39 SCIVOLANZA PERICOLOSA - DANGEROUS SLIPPERY 0,40 - μ = 0,39 SCIVOLANZA ACCETTABILE - ACCEPTABLY SLIPPERY 0,40 - μ = 0,34 ATTRITO SODDISFACENTE - SATISFACTORY FRICTION 0,35-0,40 AMBICO ECCELLENTE - EXCELLENT FRICTION </small>	$> 0,40$	$> 0,40$
	B.C.R.A. G.B.		$> 0,40$	$> 0,40$
COEFFICIENTE D'ATTRITO STATICO COEFFICIENT OF STATIC FRICTION	ASTM C 1028 (S.C.O.F)	SUP RESISTANT ($\geq 0,60$)	$> 0,60 \text{ DRY}$	$> 0,60 \text{ DRY}$
			$\geq 0,60 \text{ WET}$	$\geq 0,60 \text{ WET}$
CLASSIFICAZIONE ANTISDRUCCIUOLO NON-SLIP CLASSIFICATION	DIN 51130	INFILTRAZIONE DELL'AMBIENTE O DELLA ZONA DI LAVORO INfiltration BY THE ENVIRONMENT OR THE WORKING AREA	R10	R11
RESISTENZA ALLO SCIVOLAMENTO SLIP RESISTANCE	DIN 51097	-	A	A+B

VARIAZIONE CROMATICA SHADE VARIATION	V2	aspetto uniforme uniform appearance V1	lieve variazione slight variation V2	moderata variazione moderate variation V3	forte variazione substantial variation V4
---	----	--	--	---	---

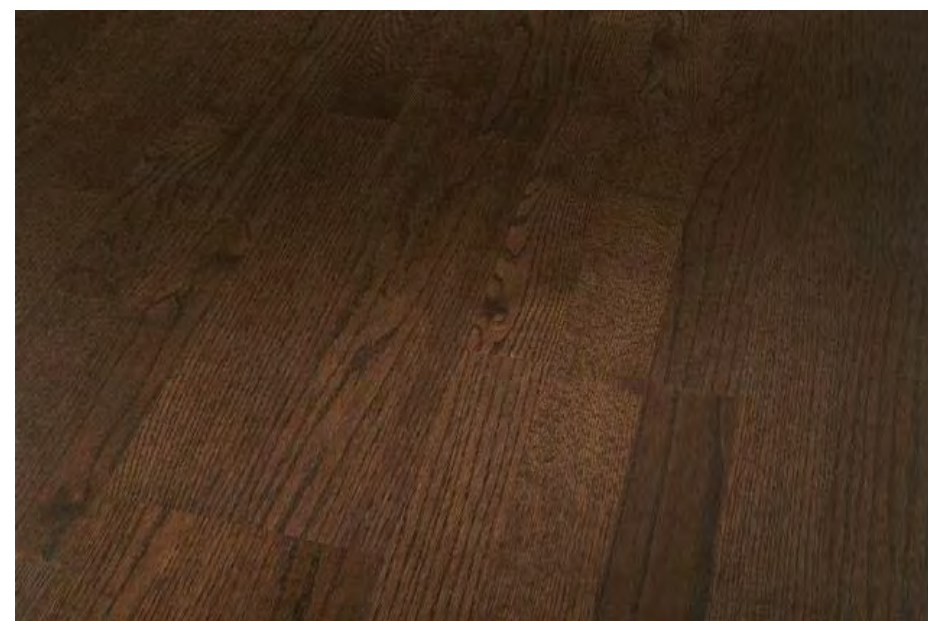



ANASPEL LTD

**12 Dorrington Str.
Holborn
London EC1N 7TB
UK**

**Tel:+44(0)20 3126 4950, CY Mob.00357-99630650, UK Mob:+44(0)781898 0000
nicolaid@spidernet.com.cy
george.palos@surveyors-valuers.co.uk**